

BIESSE SELCO PLAST WN 6

Numerical control beam saws

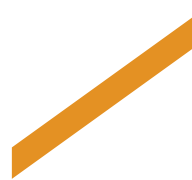

When competitiveness
means excellent
machining quality



Made **In** Biesse

The market demands

a change in manufacturing processes, enabling companies to **accept the largest possible number of orders**. This is coupled with the need to maintain high quality standards whilst offering product customisation with **quick and defined delivery times**.

Biesse responds

with **technological solutions** which underline and support technical expertise, as well as process and material knowledge. **SELCO WN 6** is a professional range of beam saws with one cutting line, designed to produce medium-sized batches.

- ✓ **High quality and cutting accuracy.**
- ✓ **Reduced tool changeover time.**
- ✓ **Technological solutions for every machining need.**

The result of technological
research for top-class
performance



SELCO PLAST WN 6

Numerical control beam saws

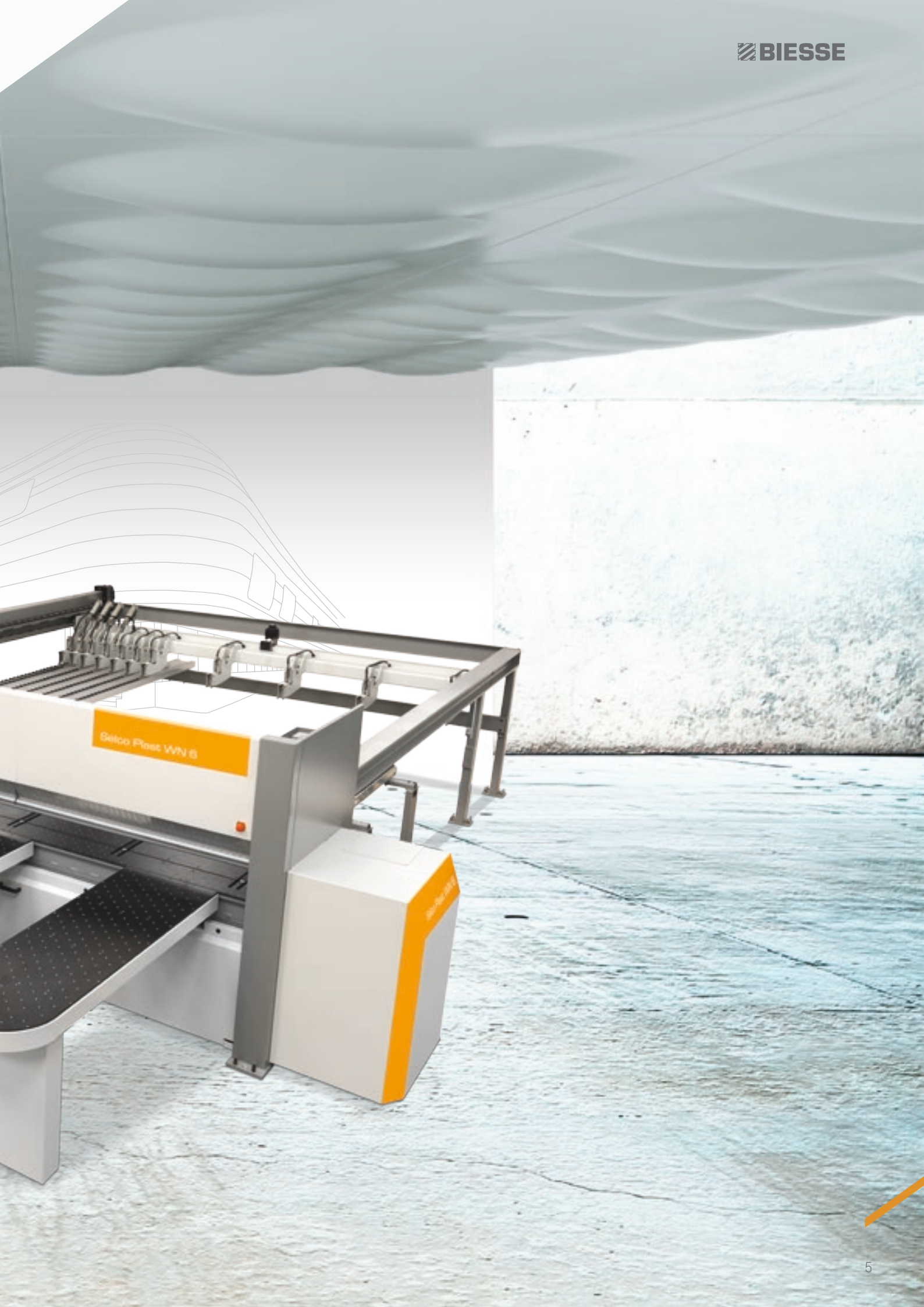

Cutting quality

The protrusion of the main blade and the opening of the presser are automatically adjusted by the numerical control on the basis of the thickness of the book to be cut, thereby obtaining the best cutting quality in all working conditions.



Perfect stability, thanks to the solid steel structure of the **base** sustained by robust supports. The slide guides of the blade-holder carriage are located on the same beam to ensure they are straight and perfectly parallel.

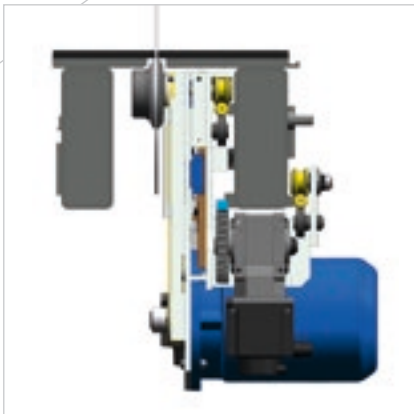

The excellent balancing of the tool-holder carriage (thanks to the shape of the base and the positioning of the guides and wheels) means there are no blade vibrations at all, and the carriage makes an extremely linear movement.

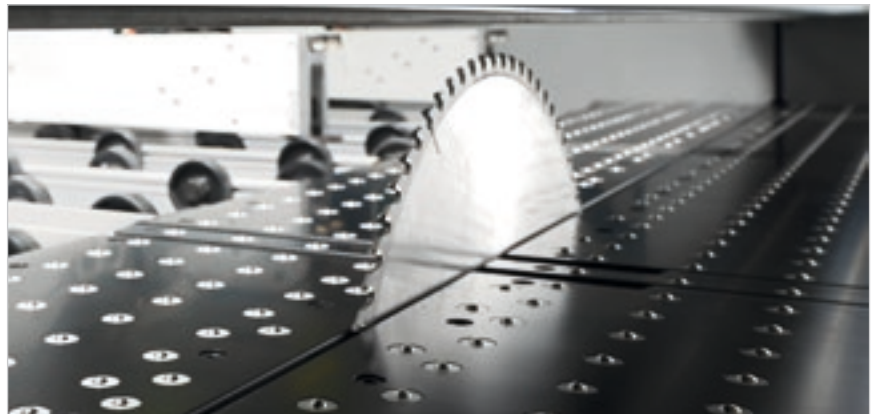

Top product quality, thanks to the **air cushioned working surface**, which protects delicate materials. In addition, this characteristic ensures the surface next to the blade is kept constantly clean.

Maximum cutting quality, a longer blade lifespan, and reduced maintenance costs.

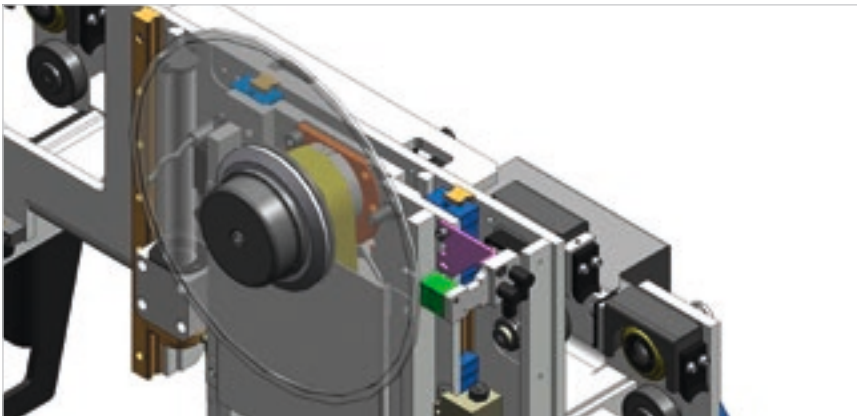

Blade carriage with inverter motor and nozzle for blade lubrication and cooling. It is equipped with an anti-slide device that controls the position and the number of revolutions of the blade, intervening to adjust the advance speed.



Cutting line closure system to prevent trim cuts from falling into the machine and fouling the blade path.

Precision cutting



The robust pushing carriage driven by a brushless motor on hardened racks and cemented gear wheels, together with the magnetic band positioning control and component locking via independent grippers, guarantee the utmost cutting precision and quality for panels of various formats and sizes.

SELCO TECHNOLOGY

Selco beam saws' cutting-edge technology responds to the needs of operators who process technological materials. A perfect combination of Biesse innovation and Italian genius.

Maximum machining operation precision



Fast, accurate positioning of the panels for optimum cutting precision, thanks to the robust **pusher carriage** activated by a brushless motor. The slide surface below the pushing device is fitted with independent rollers to avoid marking delicate surfaced panels.



Independent and self-levelling **grippers**, ensure the book is firmly secured. Their specific design and machine logic enable the full ejection of cut panels from the cutting line, making it easier for the operator to handle both panels and waste.

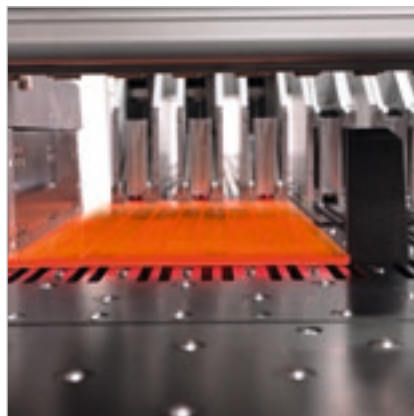

Perfect alignment of very thin and/or flexible panels, minimising cycle times thanks to the **side alignment stop** integrated in the blade carriage.

Reduced tool changeover time



Quick Change system (patented) for the swift release of blades without tools.

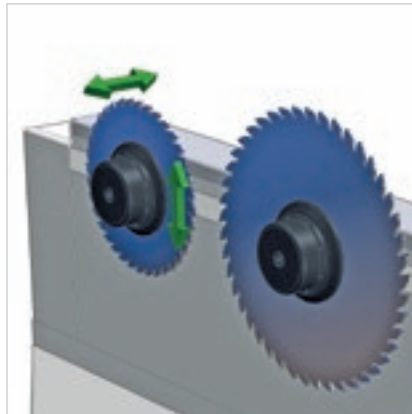

Fast, accurate setting of the scoring and main blades, using **Digiset system**. The system also stores the information for each set of blades, ensuring repeatable and accurate alignment every time.

A photograph of three business professionals in a meeting. A man in a dark suit and tie is on the left, looking towards the center. A woman in a light grey blazer is in the middle, with her hands clasped and looking towards the right. A woman with blonde hair is on the right, smiling. The background is a bright, modern office setting with a whiteboard and a potted plant. The image is partially obscured by a white diagonal line that runs from the top right towards the bottom left.

Lean and efficient production flow

Design of integrated production lines
that are over 100-metres long

BiesseSystems provides a full project consultancy and management service to companies who wish to implement integrated technology solutions for their manufacturing processes.

A team of sector experts, capable of understanding and anticipating company needs, work with the customer from inception through to system installation and commissioning.

Over 300 systems
sold worldwide.

- ✓ Design and installation of turn-key systems.
- ✓ Design and installation of automated and integrated production lines.
- ✓ Upgrading, refurbishment and integration of pre-existing production systems.



Ease of use and practicality

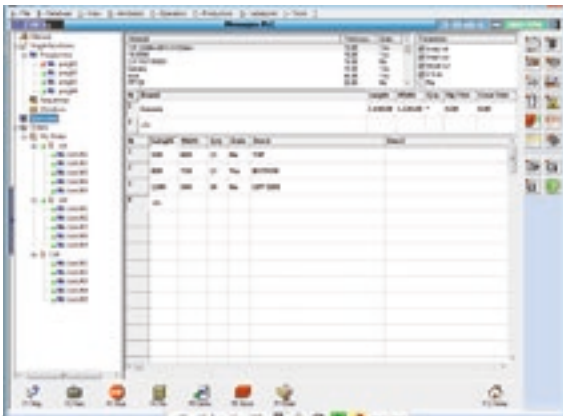
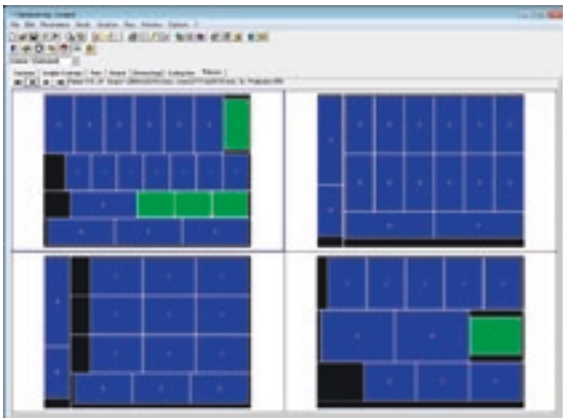

Labelling.

A special software creates individual labels and prints them in real time, on the machine. The information available can also be printed in bar code form.

Technical specifications

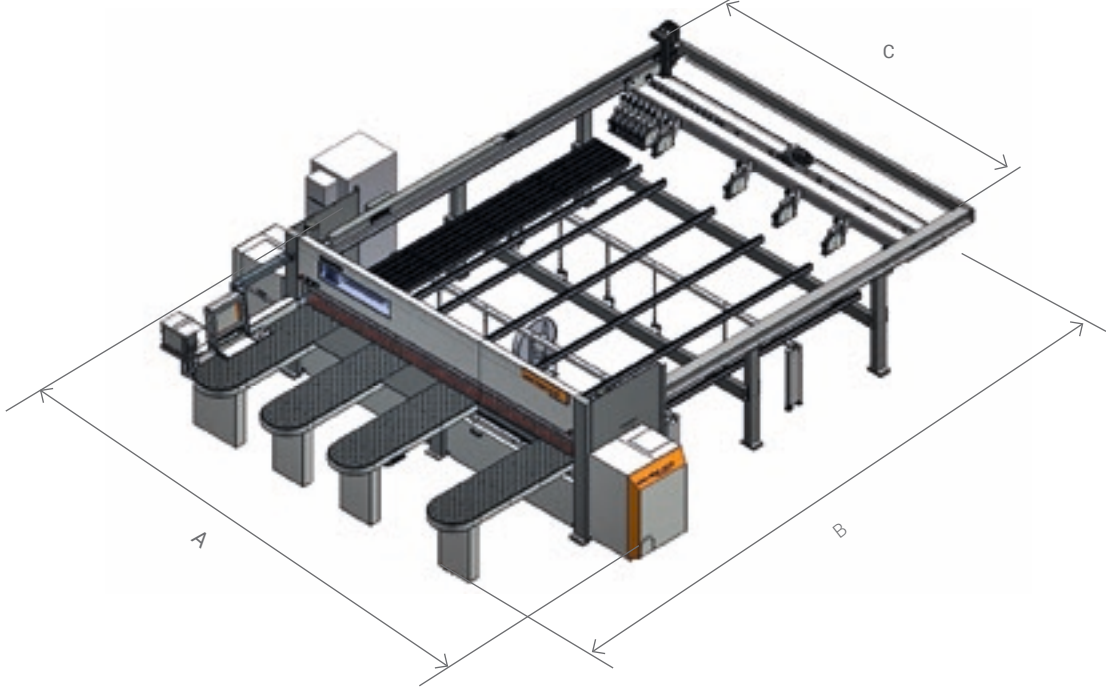

WN 610 - 650

	3200X3200	4500X4500
	mm	mm
A	5350	6650
B	6980	8280
C	3630	4930

The technical specifications and drawings are non-binding. Some photos may show machines equipped with optional features. Biesse Spa reserves the right to carry out modifications without prior notice.

A-weighted surface sound pressure level (L_{pfA}) during machining for operator workstation on vane-pump machine L_{pa}=83dB(A) L_{wa}=106dB(A) A-weighted sound-pressure level (L_{pA}) for operator workstation and sound power level (L_{wA}) during machining on cam-pump machine L_{wa}=83dB(A) L_{wa}=106dB(A) K measurement uncertainty dB(A) 4

The measurement was carried out in compliance with UNI EN 848-3:2007, UNI EN ISO 3746: 2009 (sound power) and UNI EN ISO 11202: 2009 (sound pressure levels at workstation) during panel machining. The noise levels shown are emission levels and do not necessarily correspond to safe operation levels. Despite the fact that there is a relationship between emission and exposure levels, this may not be used in a reliable manner to establish whether further measures need to be taken. The factors determining the exposure level for the workforce include length of exposure, work environment characteristics, other sources of dust and noise, etc. i.e. the number of other adjoining machines and processes. At any rate, the above information will enable the operator to better evaluate dangers and risks.

Service & Parts

Direct, seamless co-ordination of service requests between Service and Parts.
Support for Key Customers by dedicated Biesse personnel, either in-house and/or at the customer's site.

Biesse Service

- ✓ Machine and system installation and commissioning.
- ✓ Training centre dedicated to Biesse Field engineers, subsidiary and dealer personnel; client training directly at client's site.
- ✓ Overhaul, upgrade, repair and maintenance.
- ✓ Remote troubleshooting and diagnostics.
- ✓ Software upgrade.

500 / Biesse Field engineers in Italy and worldwide.

50 / Biesse engineers manning a Teleservice Centre.

550 / Certified Dealer engineers.

120 / Training courses in a variety of languages every year.

The Biesse Group promotes, nurtures and develops close and constructive relationships with customers in order to better understand their needs and improve its products and after-sales service through two dedicated areas: Biesse Service and Biesse Parts.

With its global network and highly specialised team, it offers technical service and machine/component spares anywhere in the world on-site and 24/7 on-line.



Biesse Parts

- ✓ Original Biesse spares and spare kits customised for different machine models.
- ✓ Spare part identification support.
- ✓ Offices of DHL, UPS and GLS logistics partners located within the Biesse spare part warehouse, with multiple daily pick-ups.
- ✓ Order fulfilment time optimised thanks to a global distribution network with de-localised, automated warehouses.

87% / of downtime machine orders fulfilled within 24 hours.

95% / of orders delivered in full on time.

100 / spare part staff in Italy and worldwide.

500 / orders processed every day.



BIESSEGROUP

 **BIESSE**

 **INTERMAC**

 **DIAMUT**

MECHATRONICS

In

1 industrial group, 4 divisions
and 8 production sites

How

€ 14 million p/a in R&D and 200 patents registered

Where

33 branches and 300 agents/selected resellers

With

customers in 120 countries: manufacturers of furniture, design items, and door/window frames, producers of components for the building, nautical and aerospace industries

We

3000 employees throughout the world

